



2 WIDE/ 3 WIDE CHANGER TRAY

Instruction Manual

Congratulations!

You are now the owner of a Nurseryworks product...a line of modern baby furniture that redefines the nursery. Nurseryworks' products are designed with both style and functionality in mind, and we hope it becomes a source of pleasure for you and your family. Quality material, workmanship and pride have gone into these products. Proper assembly is important to ensure a safe and comfortable end result for your baby. Please read all instructions before assembly, and keep instructions for future use.

2 WIDE/ 3 WIDE CHANGER TRAY

Hardware and Parts List

Hardware & Parts	Ref.No	Description
------------------	--------	-------------

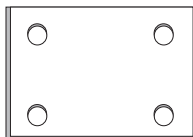

Cx2

Bracket



Dx8

**Screw
(15mm/0.6")**

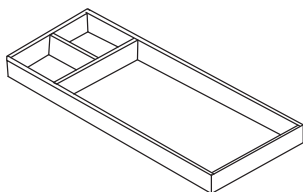

5x1

Top Tray

Please note that screw D requires a Phillips Head Screw driver which is not provided.

- ★ Be sure you follow the instructions in the order that they appear.
To avoid possible scratching, assemble furniture on a soft surface.
For instance on a carpet or blanket.
- Be aware that you can use both ends of the Allen wrench.
For instance, use it lengthwise to get into tighter corners.
- Be careful not to over tighten screws.

Installation of Changer Tray on 2 Wide



- Place Tray ⑤ on top of the Cube and Drawers as shown. Line up the small screw holes on the back of the tray with the small screw holes on the back of the Cube and Drawers.
- Attach Tray ⑤ using the 2 C Brackets. Screw them into place with 4 D screws per bracket.
- 8 D Screws total.
- Tighten all screws with Phillips Head Screw driver.

Parts Check



D Screw
(15 mm/0.6")

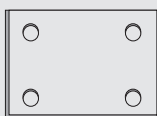

C Bracket

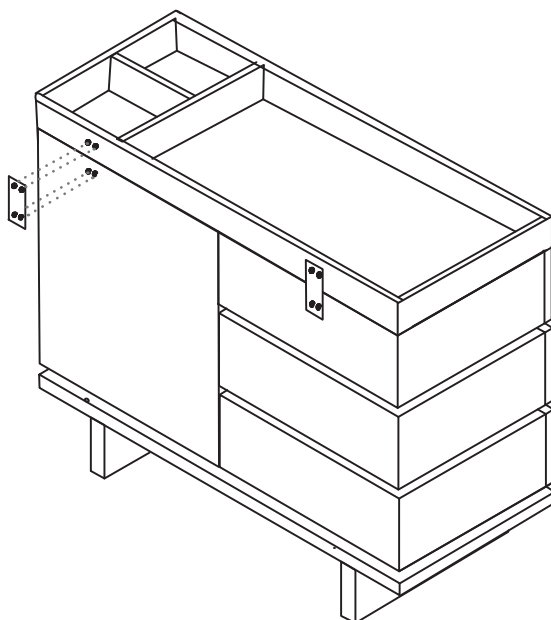

Installation of Changer Tray on 3 Wide



Option A - Tray on left side

- Place Tray ⑤ on top left side of the Drawers as shown. Line up the small screw holes on the back of the tray with the small screw holes on the back of the Cube and Drawers.
- Attach Tray ⑤ using the 2 C Brackets. Screw them into place with 4 D screws per bracket.
- 8 D Screws total.
- Tighten all screws with Phillips Head Screw driver.

Parts Check

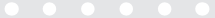

D Screw
(15 mm/0.6")

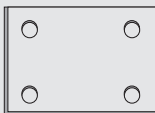

C Bracket

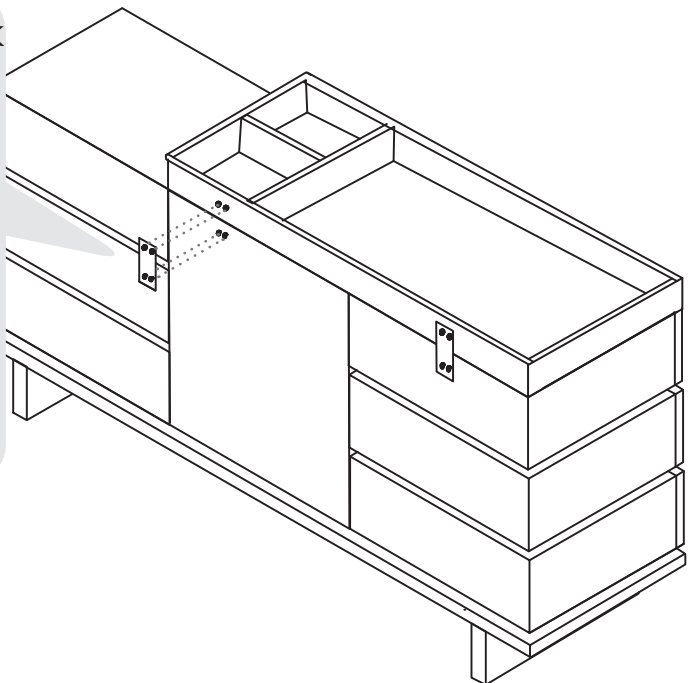

Installation of Changer Tray on 3 Wide



Option B - Tray on right side

- Place Tray ⑤ on top right side of the Drawers as shown. Line up the small screw holes on the back of the tray with the small screw holes on the back of the Cube and Drawers.
- Attach Tray ⑤ using the 2 C Brackets. Screw them into place with 4 D screws per bracket.
- 8 D Screws total.
- Tighten all screws with Phillips Head Screw driver.

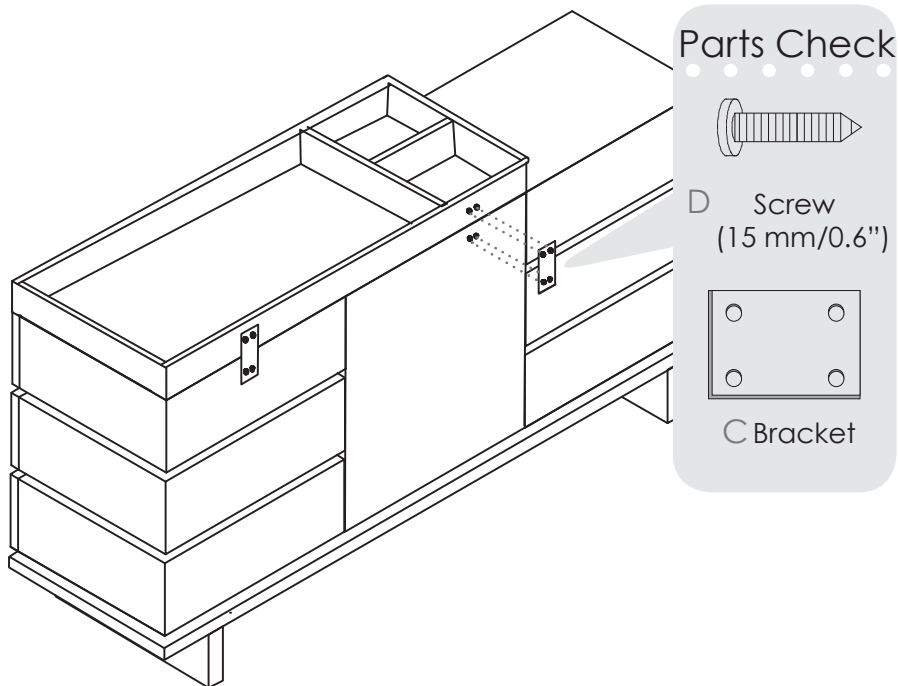



www.nurseryworks.net